

2 SEATER SOFA WITH ARMS

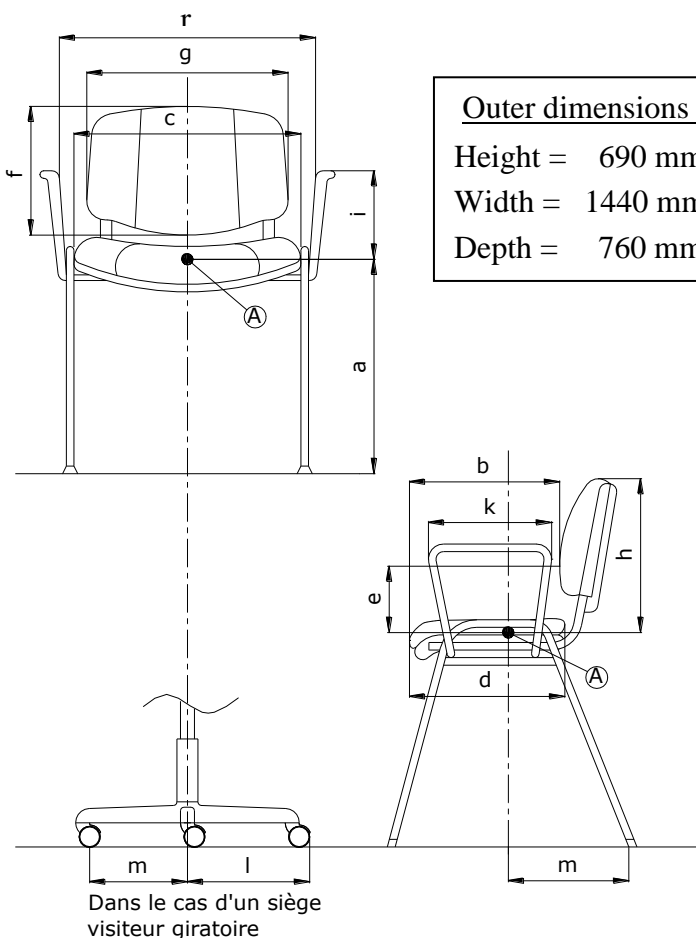

Standard's generic scheme



| Functional dimension | | Effective dimensions |
|---|---|----------------------|
| Seat's height | | |
| Fixed | a | 365 |
| Adjustable | | - |
| Seat's depth | b | 560 |
| Seat's width | c | 615 |
| Useful width between armrests | r | 1200 |
| Seat's plate depth | d | 550 |
| Backrest's most prominent point over seat | e | 150 |
| Backrest's height | f | 390 |
| Backrest useful width | | |
| Visitor chair | g | - |
| Reception chair | | 615 |
| Backrest's highest point over seat | h | 315 |
| Armrest's height over seat | i | 305 |
| Armrests' length | k | 750 |
| Base branch's length | l | - |
| Stability | t | 380 |

| Worksheet | Elaboration date | Validity conditions | Page |
|----------------|------------------|---|------|
| FT 760 OXY1 20 | 20 April 2009 | The data provided by this worksheet is applicable on its date of elaboration. Sokoa reserves the right to carry out any improvement that is considered useful, without having to inform customers about such changes as long as the main technical features of the products are not modified. | 1/2 |

| | | |
|--|--------------------------|------------|
|  | PRODUCT WORKSHEET | N° |
| | OXY1/20 | 760 |

DESCRIPTION

| | | |
|---------------|--------------|--|
| Shell | OXY1020CN000 | Compact seat/armrest realized with : <ul style="list-style-type: none"> • Assembled wood structure. • 2 independent Cushions for backrest made of polyether foam, density 25 Kg/m³, hardness 50, medium thickness 200 mm, on wood structure and rubber webbing. • 2 independent Cushions for seat made of polyether foam, density 35 Kg/m³, hardness 65, medium thickness 130 mm. • Armrests foam made of polyether, density 35 Kg/m³, hardness 65, glued directly on structure. • Removable cushions fixed with Velcro and zipper. • 1 steel plate rear bar, dimensions 1200x40 mm, thickness 4 mm. Silver epoxy finish. |
| | YOX3PLBAR1 | |
| Legged | | Iron feet squared tube 40x40 and height 150 mm on PE glides screwed on structure. Silver epoxy finish. |

PACKAGING, WRAPPING, WEIGHT, VOLUME:

| Net weight | Gross weight | Type of packaging | Unit / box | Box's volume | Units / pallet | Boxes / pallet | Pallet dimensions L x P x H (cm) |
|------------|--------------|-------------------|------------|---------------------|----------------|----------------|----------------------------------|
| 39,65 Kg | 44,0 Kg | assembled | 1 | 0,71 m ³ | 4 | 4 | 80 x 150 x 255 |

CARACTERISTICS:

High ranged two seater sofa with armrests.
 Fully black leather finish party contact with the user, black simili leather for backrest and lateral parts.
 Straight lines, sober design and universal. Cleaning or easy substitution of upholstered cushions.
 Also available in 3 seater version and 1 seat sofa.

LAUNCHING DATE: 01/2009.

GUARANTEE: 5 years.



All our chairs produced under the certified quality insurance system AFAQ ISO 9001/2000 n°2000/15348.3, and also under the eco-friendly management system ISO 14001/2004 n°2006/27672.2



| Worksheet | Elaboration date | Validity conditions | Page |
|----------------|------------------|---|------|
| FT 760 OXY1 20 | 20 April 2009 | The data provided by this worksheet is applicable on its date of elaboration. Sokoa reserves the right to carry out any improvement that is considered useful, without having to inform customers about such changes as long as the main technical features of the products are not modified. | 2/2 |